

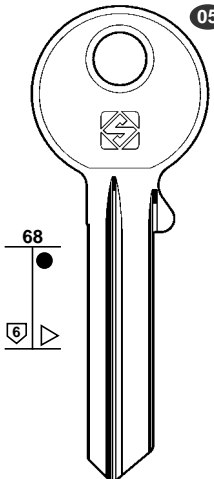

















































































PER:
FOR:

CES



 CE129-1 R/8	 CE129-2 Z/568	 CE129-3 1/678	 CE129-4 2/568	 CE129-5 R/7	 CE129-6 Z/68	 CE129-7 G/56
 CE129-8 G/68	 CE129-9 R/R	 CE129-10 G/5	 CE129-11 G/6	 CE129-12 3/567	 CE129-13 G/67	 CE129-14 3/R
 CE129-15 3/568	 CE129-16 Y/567	 CE129-17 G/57	 CE129-18 2/R	 CE129-19 1/56	 CE129-20 Y/68	 CE129-21 1/67
 CE129-22 3/68	 CE129-23 G/678	 CE129-24 3/58	 CE129-25 3/678	 CE129-26 4/578	 CE129-27 4/568	 CE129-28 3/57
 CE129-30 4/678	 CE129-31 3/578	 CE129-32 2/57	 CE129-33 Z/67	 CE129-34 G/578	 CE129-35 1/567	 CE129-36 1/G
 CE129-38 X/R	 CE129-39 4/78	 CE129-40 1/568	 CE129-41 G/8	 CE129-42 G/7	 CE129-43 X/6	 CE129-44 4/56
 CE129-46 Z/7	 CE129-47 2/56	 CE129-48 G/58	 CE129-49 2/67	 CE129-50 2/68	 CE129-51 4/567	 CE129-52 4/G
 CE129-54 X/G	 CE129-55 3/78	 CE129-56 Z/5	 CE129-57 2/G	 CE129-58 2/578	 CE129-59 Z/G	 CE129-60 Z/56
 CE129-62 X/58	 CE129-63 Y/67	 CE129-64 4/R	 CE129-65 Y/56	 CE129-66 Z/567	 CE129-67 Y/G	 CE129-68 Z/78
 CE129-70 2/58	 CE129-71 X/7	 CE129-72 1/58	 CE129-73 4/57	 CE129-74 X/67	 CE129-75 Y/6	 CE129-76 3/56
 CE129-78 Y/57	 CE129-79 Y/8	 CE129-80 Z/8	 CE129-81 2/567	 CE129-82 X/8	 CE129-83 Y/58	 CE129-84 3/67
 CE129-86 Z/6	 CE129-87 3/G	 CE129-88 2/678	 CE129-89 X/5			

BODA - THÖMEE



1

PER / FOR

BODA (SF)

 CES (1-2)

CES (D)

BODA
THÖMEE

01

COMMERCIAL GROUP
GRUPPO COMMERCIALE
PREISEGRUPPE
GROUPE COMMERCIAL
GRUPO COMMERCIAL

www.silca.it



2

PER / FOR

BURG (D)

CES (D)
BODA
THÖMEE

DOM (D)

THÖMEE (D)



CES (1-2)

WAUS (P)

PER:
FOR:

CES

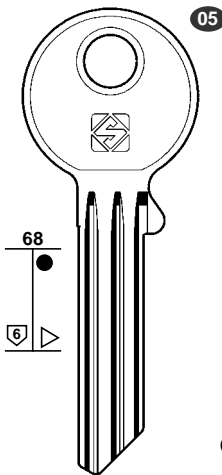

CE130-1
C/2

CE130-2
B/2

CE130-3
B/1

CE130-4
C/4

CE130-5
A/4

CE130-6
A/5

CE130-7
C/5

CE130-8
C/1

CE130-9
A/2

CE130-10
D/1

CE130-11
A/34

CE130-12
B/3

CE130-13
X/678

CE130-14
1/68

CE130-15
4/67

CE130-16
4/68

CE130-17
AB5

CE130-18
B1/5

CE130-19
C1/5

CE130-20
AD1

CE130-21
AD4

CE130-22
A1-5

CE130-23
AB1-3

CE130-24
D1-5

CE130-25
D/2

CE130-26
D/5

CE130-27
D/4

CE130-28
A/3

CE130-29
C/34

CE130-30
C/3

CE130-31
B/34

CE130-32
B/5

CE130-33
B/4

CE130-34
D/3

CE130-35
A/1

BODA - THÖMEE

PER:
FOR:

BURG

DOM

WAUS

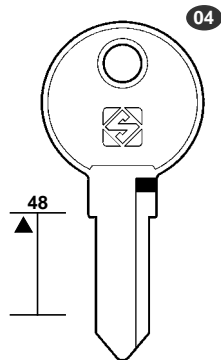

BUR31

BUR31R

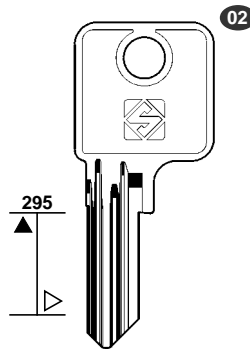

DM137

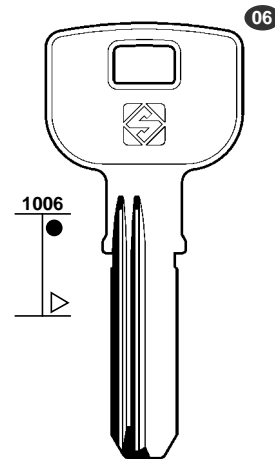

WU1R



01

COMMERCIAL GROUP
GRUPPO COMMERCIALE
PREISEGRUPPE
GROUPE COMMERCIAL
GRUPO COMMERCIAL

www.silca.it

PER: FOR: **HUF** **KIA** **SSANGYONG**

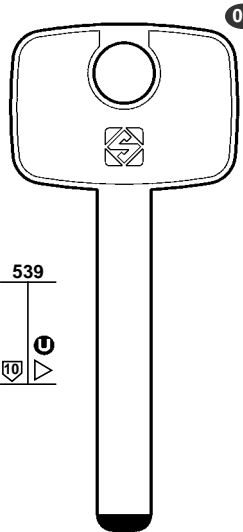

HU111

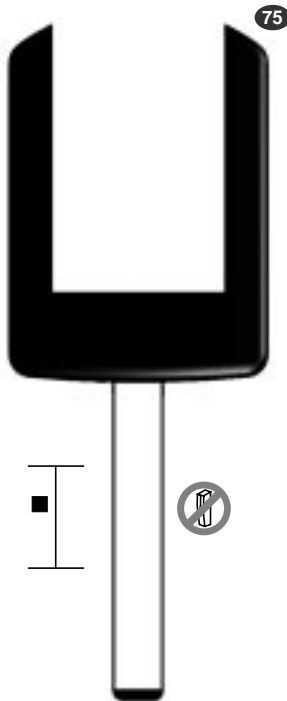

HU100BT12

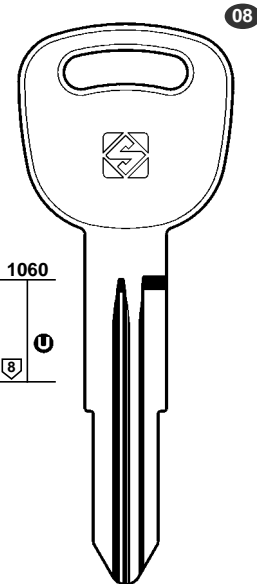

KIA5

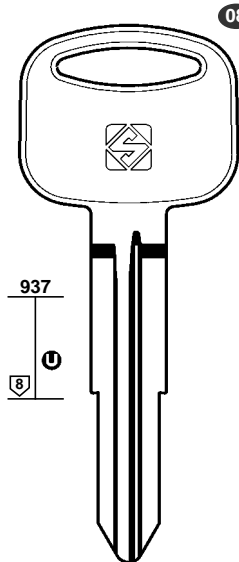

SSY3

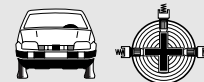

3

PER / FOR

HUF (D)

KIA (ROK)

SSANGYONG (ROK)

BKS (D)

YALE (5)

BURG WÄCHTER (D)
TRIOVING

PER: FOR: **BURG WÄCHTER**

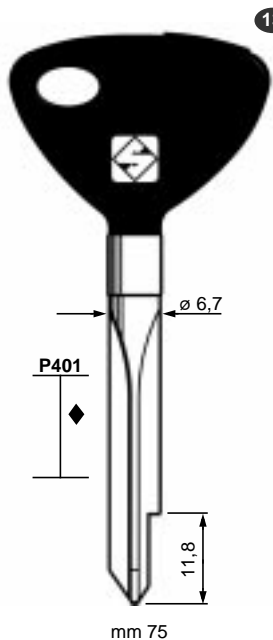

mm 75

XBW1P

TRIOVING

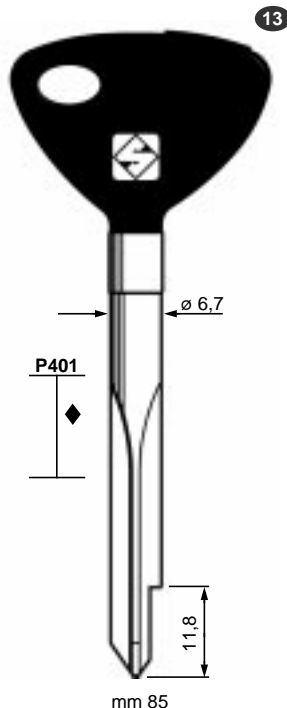

mm 85

XBW2P

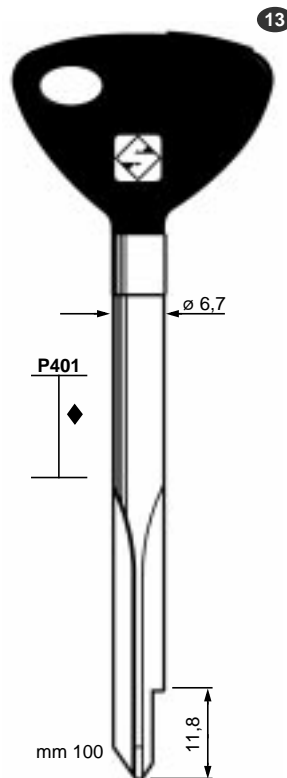

mm 100

XBW3P

01

COMMERCIAL GROUP
GRUPPO COMMERCIALE
PREISEGRUPPE
GROUPE COMMERCIAL
GRUPO COMMERCIAL

www.silca.it



4

PER / FOR

BURG WÄCHTER (D)

C.R. (I)

YALE (5)

FIAM (I)

+ YALE (5)

GERA (D)

ISEO (I)

NEMEF (NL)

TRIOVING (N)

BURG WÄCHTER (3)

PER: BURG WÄCHTER
FOR:

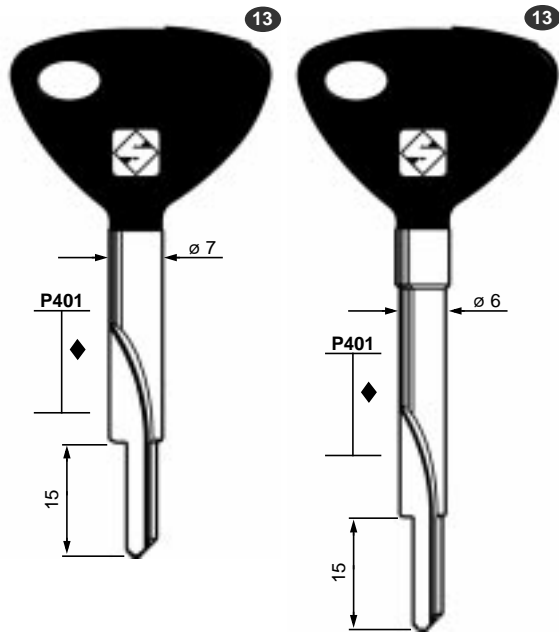

FIAM

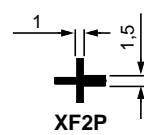
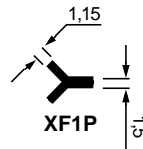
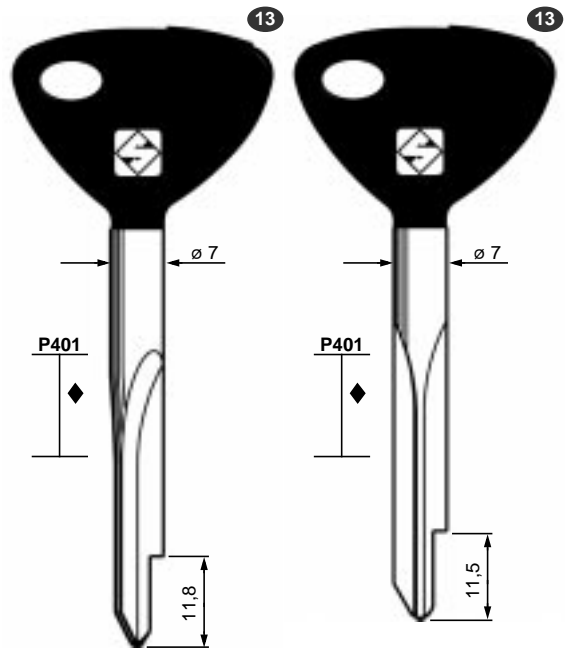

PER: GERA
FOR:

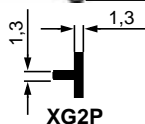
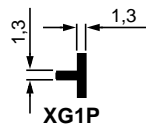
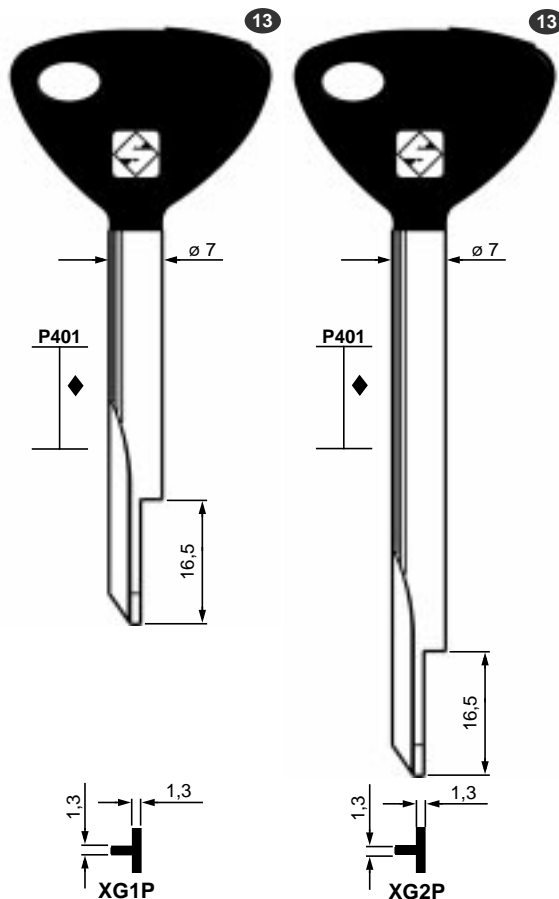

ISEO

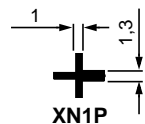
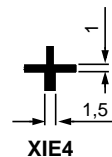
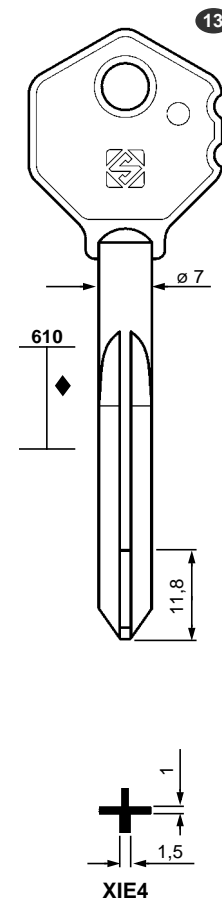

NEMEF

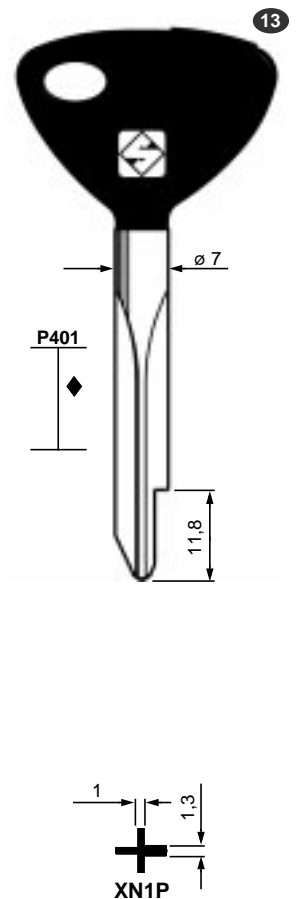

01

COMMERCIAL GROUP
GRUPPO COMMERCIALE
PREISEGRUPPE
GROUPE COMMERCIAL
GRUPO COMMERCIAL

www.silca.it

PER:
FOR:

YALE

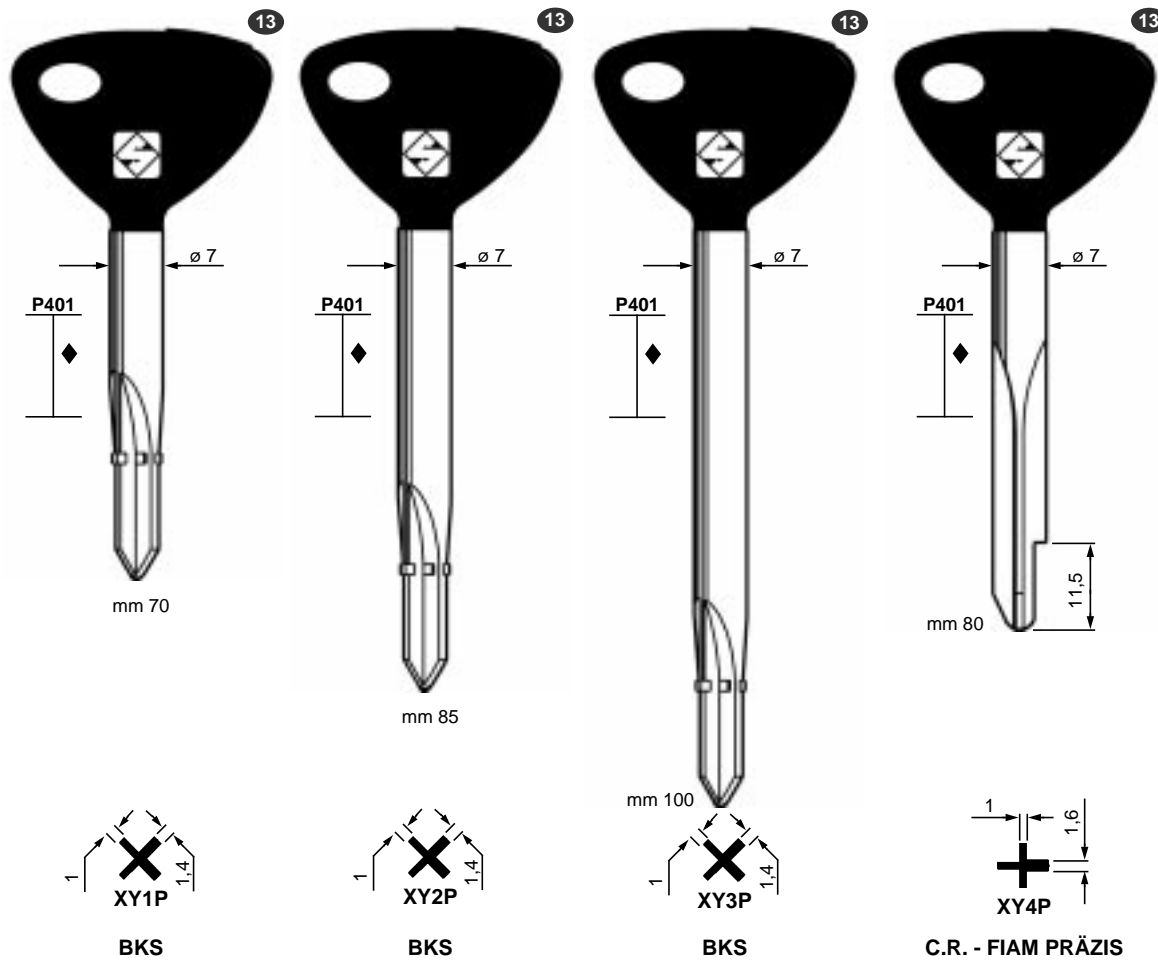

5

PER / FOR

YALE (D)
BKS

YALE (I)
C.R.
FIAM PRÄZIS

PER:
FOR:

YALE

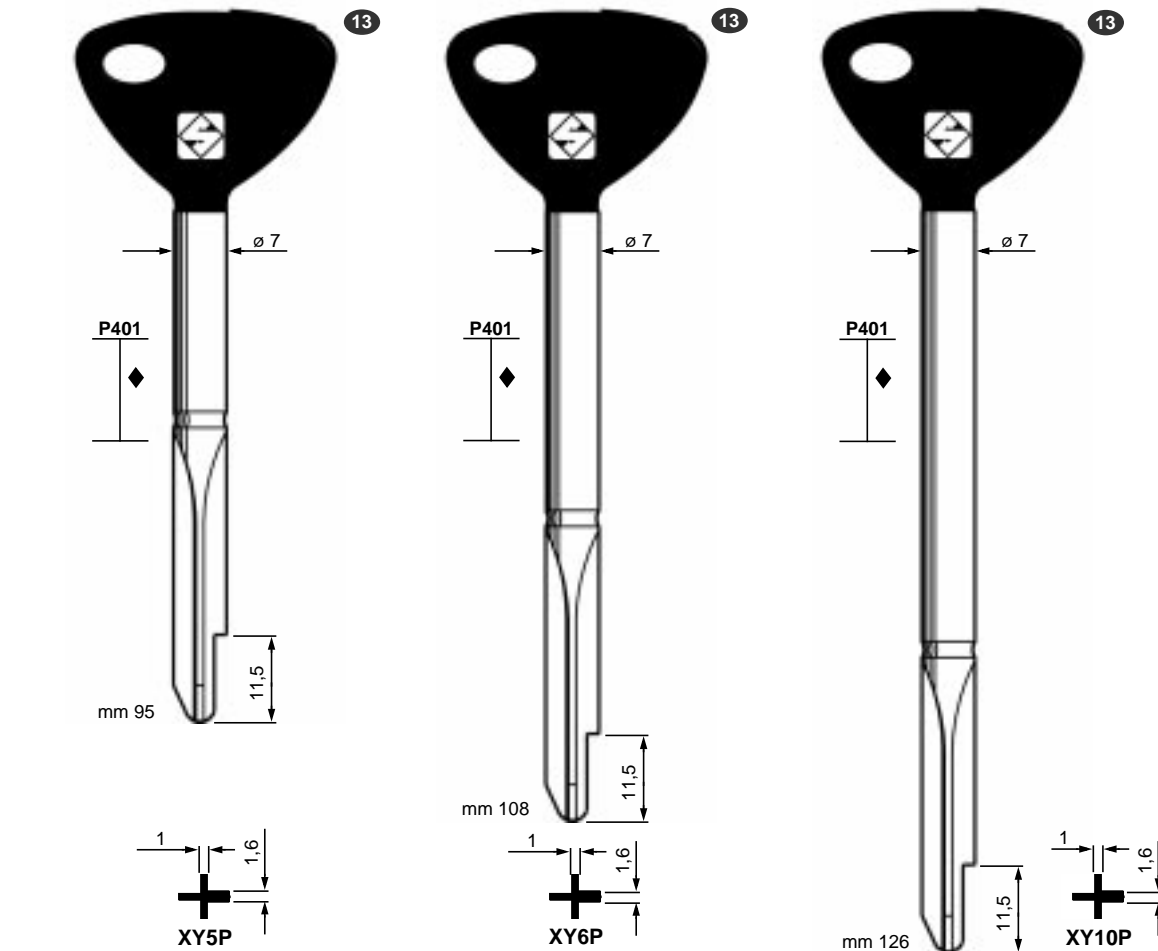

01

COMMERCIAL GROUP
GRUPPO COMMERCIALE
PREISEGRUPPE
GROUPE COMMERCIAL
GRUPO COMMERCIAL

www.silca.it

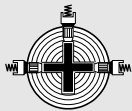

6

PER / FOR

ZEISS IKON (D)

PER:
FOR:

ZEISS IKON

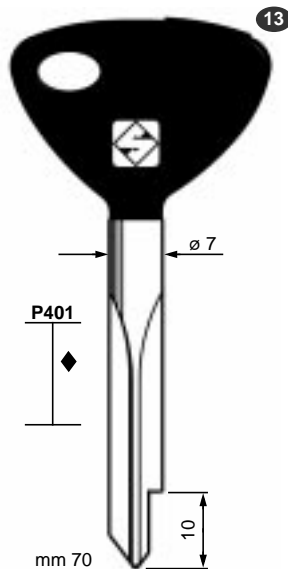

mm 70

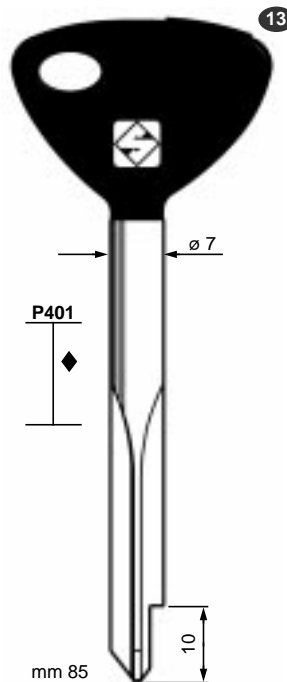

mm 85

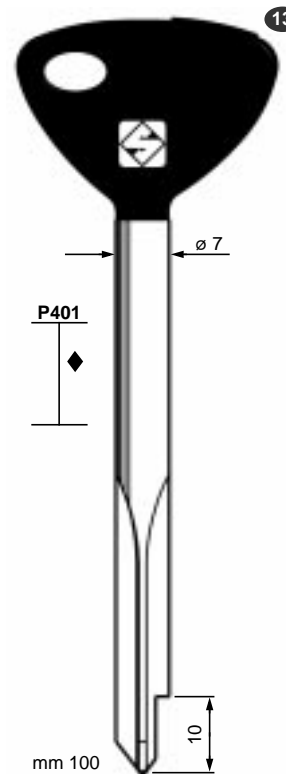

mm 100

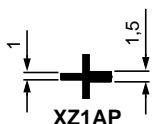

XZ1AP

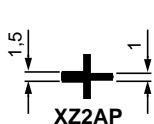

XZ2AP

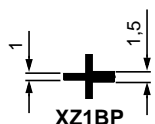

XZ1BP

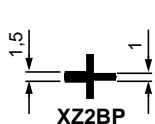

XZ2BP

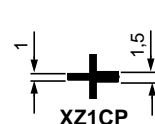

XZ1CP

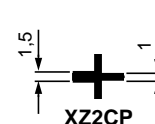

XZ2CP

PER:
FOR:

ZEISS IKON

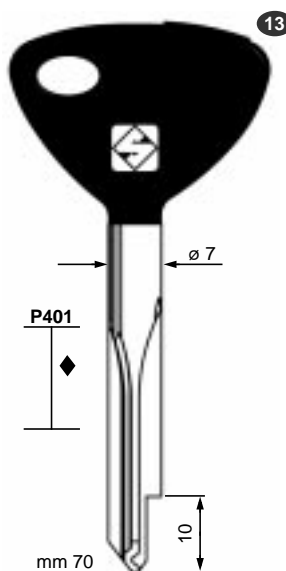

mm 70

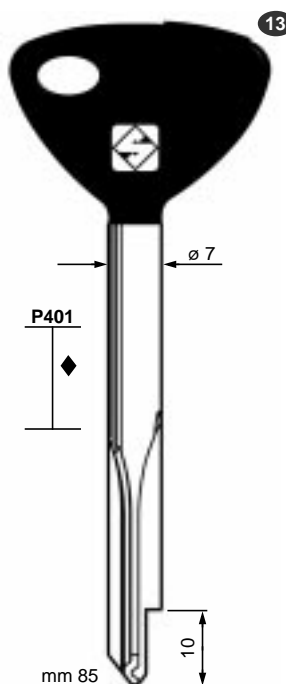

mm 85

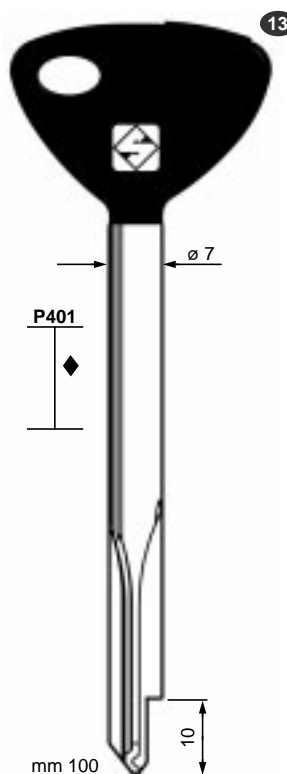

mm 100

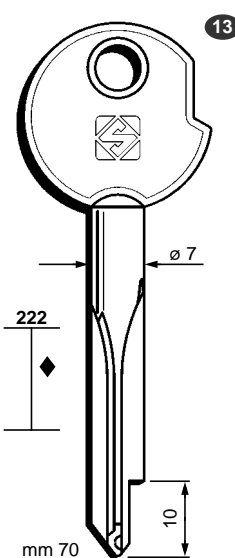

mm 70



XZ3AP
S9



XZ3BP
S9



XZ3CP
S9







XZ5A
S9











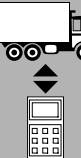
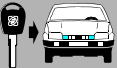
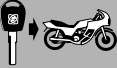

01

COMMERCIAL GROUP
GRUPPO COMMERCIALE
PREISEGRUPPE
GROUPE COMMERCIAL
GRUPO COMMERCIAL

www.silca.it

TRANSPONDER LEGEND

1		<p>Make and model Marca e modello Marke und Modell Marque et modèle Marca y modelo</p>	5		<ul style="list-style-type: none"> - M = MASTER: llave primaria, abre todas las cerraduras; - V = VALET: llave secundaria, sólo para encendido vehículo y apertura portezuela. - P = tapón de la cabeza de la llave - R = tapón rojo; - W = tapón blanco; - B = tapón azul; - HK = color de la cabeza de la llave.
2		<p>In production from... Fabbricata dal... Hergestellt seit... Fabriquée du... Fabricada desde...</p>	6		<ul style="list-style-type: none"> • Type of transponder on the original key(1) • Tipo di transponder presente nella chiave originale(1) • Transpondertyp im Originalschlüssel(1) • Type de transpondeur présent dans la clé originale(1) • Tipo de transponder presente en la llave original(1)
2/a		<p>In production until... Fabbricata fino al... Hergestellt bis... Fabriquée jusqu'au... Fabricada hasta...</p>	9		<ul style="list-style-type: none"> • Identification of transponder type by RW2 (with stand alone or PC) (2) • Identificazione tipo di transponder tramite RW2 (sia in modalità stand alone che con PC) (2) • Identifizierung des Transpondertyps mit Hilfe der RW2 (sowohl Stand Alone als auch mit PC) (2) • Identification du type de transpondeur par RW2 (tant en mode "stand alone" qu'avec PC) (2) • Identificación tipo de transponder por medio de RW2 (tanto en modalidad stand alone como con PC) (2)
3		<p>Silca key reference Referenza chiave Silca Silca-Schlüssel-Referenz Référence clé Silca Referencia llave Silca</p>	9/a		<ul style="list-style-type: none"> • Identification of transponder type by RW2+TEX Code (3) • Identificazione tipo di transponder tramite RW2+TEX Code (3) • Identifizierung des Transpondertyps mit Hilfe der RW2+TEX Code (3) • Identification du type de transpondeur par RW2+TEX Code (3) • Identificación tipo de transponder por medio de RW2+TEX Code (3)
5		<ul style="list-style-type: none"> - M = MASTER: primary key, opens all locks; - V = VALET: secondary key, for vehicle ignition and door opening only; - P = key head plug - R = red plug; - W = white plug; - B = Blue plug; - HK= key head color. <ul style="list-style-type: none"> - M = MASTER: chiave primaria, apre tutte le serrature; - V = VALET: chiave secondaria, solo per accensione auto e apertura portiera; - P = tappo testa chiave; - R = tappo rosso; - W = tappo bianco; - B = tappo blu; - HK= colore testa chiave. <ul style="list-style-type: none"> - M = MASTER: Primärschlüssel, öffnet alle Schlösser; - V = VALET: Sekundärschlüssel nur zum Starten des Schlüssels und Öffnen der Tür; - P = Gehäuse - R = Rote Gehäuse; - W = Weisse Gehäuse; - B = Blaue Gehäuse; - HK= Kopf-Farbe. <ul style="list-style-type: none"> - M = MASTER: clé primaire ouvrant toutes les serrures; - V = VALET: clé secondaire pour allumage voiture et ouverture de la portière seulement. - P = bouchon tête clé - R = bouchon rouge; - W = bouchon blanche; - B = bouchon bleue; - HK= couleur tête clé. 	10		<ul style="list-style-type: none"> • Copy of key by RW2 (version 23.0) The symbols show: <ul style="list-style-type: none"> - Y: can be copied with RW2 (RW2 Stand Alone); - ID: The RW2 (latest version in Silca) is able to duplicate the ID (part of the electronic code) of Philips Crypto transponders. • Copia della chiave tramite RW2 (versione 23.0) I simboli identificano: <ul style="list-style-type: none"> - Y: copiabile con RW2 (RW2 Stand Alone); - ID: RW2 (ultima versione presente in Silca) è in grado di duplicare l'identificatore (parte del codice elettronico) del transponder Crypto Philips. • Kopie des Schlüssels mit RW2 (Version 23.0) Die Symbole zeigen an: <ul style="list-style-type: none"> - Y: kopierbar mit RW2 (RW2 Stand Alone); - ID: RW2 (letzte Version von Silca) kopiert den Identifikator (Teil des elektronischen Codes) des Transponders Crypto Philips.

10	 <p>RW2</p>	<ul style="list-style-type: none"> • Copie de la clé par RW2 (version 23.0) Les symboles indiquent: <ul style="list-style-type: none"> - Y: copiable avec RW2 (RW2 Stand Alone); - ID: RW2 (dernière version présente chez Silca) est en mesure de reproduire l'identificateur (partie du code électronique) du transpondeur Crypto Philips. • Copia de la llave por medio de RW2 (versión 23.0) Los símbolos identifican: <ul style="list-style-type: none"> - Y: copiable con RW2 (RW2 Stand Alone); - ID: RW2 (última versión presente en Silca) es capaz de duplicar el identificador (parte del código electrónico) del transponder Crypto Philips. 		<ul style="list-style-type: none"> • Memorization of new keys in vehicle central immobilizer system: <ul style="list-style-type: none"> - Sd: only through dealer, using the original device; the original devices are indicated on the column 16 and are for example DART, FDS2000, PGM, etc. - Nd: Memorization procedure not available. • Memorizzazione di nuove chiavi nella centralina immobilizer dell'auto: <ul style="list-style-type: none"> - Sd: solo tramite concessionario utilizzando il dispositivo originale; i nomi dei dispositivi specifici per marca auto sono richiamati nella colonna 16 e sono per es.: DART, FDS 2000, PGM, ecc.; - Nd: non è disponibile un'eventuale procedura di memorizzazione. • Speicherung von neuen Schlüsseln in der Steuerzentrale des Autos: <ul style="list-style-type: none"> - Sd: nur durch den Händler mit Hilfe der Originalvorrichtung; Die Namen der spezifischen Vorrichtungen gemäss der Auto-Marke sind in der Kolonne 16 erwähnt und sind zum Beispiel: DART, FDS 2000, PGM, ecc.; - Nd: kein Speicherungsverfahren verfügbar. • Mise en mémoire de nouvelles clés dans le central immobiliseur du véhicule: <ul style="list-style-type: none"> - Sd: uniquement par l'intermédiaire du concessionnaire en utilisant le dispositif original. Les noms des dispositifs spécifiques par marque de voiture sont reportés sur la colonne 16, sont pour exemple: DART, FDS 2000, PGM, etc. - Nd: la procédure de mise en mémoire n'est pas disponible. • Memorización de nuevas llaves en la centralita immobilizer del vehículo: <ul style="list-style-type: none"> - Sd: sólo a través del concesionario utilizando el dispositivo original (Véase en la columna 16 los nombres de los dispositivos específicos por cada marca de automóvil; por ejemplo DART, FDS 2000, PGM, etc.); - Nd: no está disponible el procedimiento de memorización.
11	 <p>SA1 RW100</p>	<ul style="list-style-type: none"> • Copy of key by RW100 and SA1 • Copia della chiave tramite RW100 ed SA1 • Kopie des Schlüssels mit RW100 und SA1 • Copie de la clé par RW100 et SA1 • Copia de la llave por medio de RW100 y SA1 	16	
12	 <p>RW2 STP</p>	<ul style="list-style-type: none"> • Indicates the possibility to generate codes for new transponder keys using RW2/STP (Silca's latest vers.) (4) • Indica la possibilità di generare il codice per nuove chiavi transponder utilizzando RW2/STP (l'ultima versione presente in Silca) (4) • Zeigt an, daß der Code für neue Transponderschlüssel mit dem RW2/STP (letzte erhältliche Version) generiert werden kann (4) • Indique la possibilité de générer le code pour de nouvelles clés transponder en utilisant RW2/STP (la dernière version présente chez Silca) (4) • Indica la posibilidad de generar el código para nuevas llaves transponder utilizando RW2/STP (la última versión Silca) (4) 		<ul style="list-style-type: none"> • Memorización de nuevas llaves en la centralita immobilizer del vehículo: <ul style="list-style-type: none"> - Sd: sólo a través del concesionario utilizando el dispositivo original (Véase en la columna 16 los nombres de los dispositivos específicos por cada marca de automóvil; por ejemplo DART, FDS 2000, PGM, etc.); - Nd: no está disponible el procedimiento de memorización.
15	  	<ul style="list-style-type: none"> • Key memorization procedure on the vehicle without using devices (instructions in the STP program) • Tipo di procedura di memorizzazione della chiave sull'autovetture senza l'utilizzo di dispositivi (istruzioni all'interno del programma STP) • Speicherung des Schlüssels im Auto ohne Verwendung der Vorrichtungen (Anleitungen im Programm STP) • Procédure de mise en mémoire de la clé sur le véhicule sans utiliser de dispositifs (voir instructions dans le programme STP) • Procedimiento de memorización de la llave en el vehículo sin el uso de dispositivos (instrucciones en el interior del programa STP) 	A	 <p>Door lock Portiera Türe Portière Puerta</p>  <p>Antitheft devices for motor-cycles Antifurto per ciclomotori e motociclette Diebstahlschutz für Motorfahrrad und Motorräder Anti-vol pour cyclomoteurs/motocyclettes Antihurto para ciclomotores y motocicletas</p>
15	 	<ul style="list-style-type: none"> • Key memorization procedure on the vehicle without using devices (instructions in the STP program) • Tipo di procedura di memorizzazione della chiave sull'autovetture senza l'utilizzo di dispositivi (istruzioni all'interno del programma STP) • Speicherung des Schlüssels im Auto ohne Verwendung der Vorrichtungen (Anleitungen im Programm STP) • Procédure de mise en mémoire de la clé sur le véhicule sans utiliser de dispositifs (voir instructions dans le programme STP) • Procedimiento de memorización de la llave en el vehículo sin el uso de dispositivos (instrucciones en el interior del programa STP) 	B	 <p>Boot/Hatchback Bagagliaio/Portiera posteriore Koferraum/Hecktür Coffre/Portière postérieure Maletero/Puerta trasera</p>  <p>Cycle seat Sella Sattel Selle Silla</p>

C		Petrol cap Tappo benzina Benzintankverschluss Bouchon réservoir Tapa de gasolina
D		Drawer Cassetto Schublade Tiroir Gaveta



All the following information reported in columns 5, 6, 9, 9a, 10, 11, 12, 15, 16, are relative to car/motorcycle/truck ignition.

Tutti i simboli e le informazioni contenute nelle colonne 5, 6, 9, 9a, 10, 11, 12, 15, 16, sono relative all'accensione dell'auto/motocicletta/camion.

Alle Symbole u. Informationen in den Spalten 5, 6, 9, 9a, 10, 11, 12, 15, 16, beziehen sich auf die Zündung des Autos/Motorrads/LKW.

Tous les symboles et les informations reportées dans les colonnes 5, 6, 9, 9a, 10, 11, 12, 15, 16, sont relatifs à l'allumage de la voiture/motocyclette/camion.

Todos los símbolos y las informaciones en las columnas 5, 6, 9, 9a, 10, 11, 12, 15, 16, son relativas al encendido del coche/motocicleta/camion.

	"PH"	Transponder Philips*
	"PH / CR"	Transponder Philips* Crypto
	"MEG"	Transponder Megamos*
	"MEG / CR"	Transponder Megamos* Crypto
	"TEXAS"	Transponder Texas*
	"TEX / CR"	Transponder Texas*Crypto
	"TEMIC"	Transponder Temic*
	"MOTOR"	Transponder Motorola*
	"TEM / CR"	Transponder Temic*Crypto
	"SAAB"	Transponder Saab*

NR. Transponder

- 11 Temic* (Fiat – fixed code) (Fiat - codice fisso) (Fiat - Fixer Code) (Fiat - code fixe) (Fiat - código fijo)
- 12 Temic* (Mazda-fixed code) (Mazda - codice fisso) (Mazda - Fixer Code) (Mazda - code fixe) (Mazda - código fijo)
- 13 Megamos* (fixed code) (codice fisso) (Fixer Code) (code fixe) (código fijo)
- 21 Silca (fixed code – empty) (codice fisso - vuoto) (silca Fixer Code - leer) (fixe code - vide) (código fijo - vacío)
- 22 Silca (fixed code – empty) (codice fisso - vuoto) (silca Fixer Code - leer) (fixe code - vide) (código fijo - vacío)
- 23 Silca (fixed code – empty) (codice fisso - vuoto) (silca Fixer Code - leer) (fixe code - vide) (código fijo - vacío)
- 33 Philips* (read/ write - fixed code) (read/ write - codice fisso) (read/ write - Fixer Code) (read/ write - code fixe) (read/ write - código fijo)
- 40 Philips* Crypto (Opel*-Vauxhall*)
- 41 Philips* Crypto (Nissan*)
- 42 Philips* Crypto (VAG*)
- 44 Philips* Crypto
- 45 Philips* Crypto (Peugeot*)
- 46 Philips* Crypto (Second generation) (seconda generazione) (Zweite Generation) (Deuxième génération) (segunda generación)
- 48 Megamos* Crypto

- 53 Philips* (emulation of Megamos* for Audi*) (emulazione di Megamos* per Audi*) (simuliert Megamos* für Audi*) (émulation de Megamos* pour Audi*) (emulación de Megamos* para Audi*)
- 73 Philips* (multi block - fixed code) (multi blocco – codice fisso) (multi block - Fixer Code) (multi bloc - code fixe) (multi bloque - código fijo)
- 93 Philips* (emulation of Megamos* for Daewoo*) (emulazione di Megamos* per Daewoo*) (simuliert Megamos* für Daewoo*) (émulation de Megamos* pour Daewoo*) (emulación de Megamos* para Audi*)
- 4C Texas* (fixed code) (codice fisso) (Fixer Code) (code fixe) (código fijo)
- 4D Texas* Crypto
- 8C Temic* Crypto
- 8D per Saab* (non duplicabile) (not duplicable) (nicht kopierbar) (non reproductible) (no duplicable)

NR. Transponder

- 60 Texas* Crypto
- 61 Texas* Crypto Mitsubishi 3
- 62 Texas* Crypto Mitsubishi 2
- 63 Texas* Crypto Ford 2
- 64 Texas* Crypto (Renault <2000, Chrysler, Jeep)
- 65 Texas* Crypto (Suzuki)

	"MEG"	Megamos* (type of generation) (tipo di generazione) (Erzeugung Typ) (Type de génération) (tipo de generación)
	"B - F"	Bosch* - Fiat* (type of generation) (tipo di generazione) (Erzeugung Typ) (Type de génération) (tipo de generación)
	"S - O"	Siemens* - Opel* (type of generation) (tipo di generazione) (Erzeugung Typ) (Type de génération) (tipo de generación)
	"M - V"	Megamos* - VDO* (type of generation) (tipo di generazione) (Erzeugung Typ) (Type de génération) (tipo de generación)
	"T - F"	Temic* - Fiat* (type of generation) (tipo di generazione) (Erzeugung Typ) (Type de génération) (tipo de generación)
	"S - V"	Siemens* - Volkswagen* (type of generation) (tipo di generazione) (Erzeugung Typ) (Type de génération) (tipo de generación)
	"G - V"	PSA* - Valeo* (type of generation) (tipo di generazione) (Erzeugung Typ) (Type de génération) (tipo de generación)
	"G - C"	PSA* - CPH* (type of generation) (tipo di generazione) (Erzeugung Typ) (Type de génération) (tipo de generación)
	"N - N"	Nissan* (type of generation) (tipo di generazione) (Erzeugung Typ) (type de génération) (tipo de generación)

The keys must then be memorized in the vehicle central immobilizer system.

Le chiavi devono poi essere memorizzate nella centralina immobilizer dell'auto.

Die Schlüssel müssen anschliessend in die Steuereinheit der Wegfahrsperrung des Autos eingespeichert werden.

Les clés doivent être mises en mémoire dans le central immobiliseur du véhicule.

Las llaves deben memorizarse en la centralita immobilizer del vehículo.

(*) Registered trade marks.

Marchi registrati.

Registrierte Handelsmarken.

Marques déposées.

Marcas registradas.



