

PER: FOR:	606	DOM	MERLE	
	 <p>01</p> <p>62</p> <p>5</p> <p>SE110</p>	 <p>06</p> <p>S393</p> <p>DM139 IX5</p> 	 <p>01</p> <p>1523</p> <p>5</p> <p>MLE1</p>	 <p>01</p> <p>1523</p> <p>4</p> <p>MLE2</p>

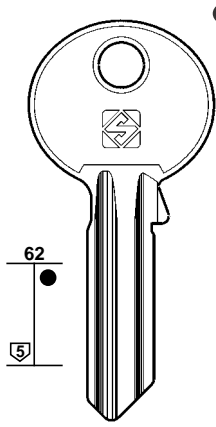
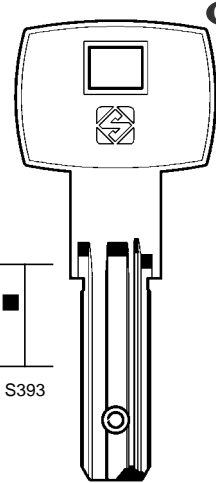
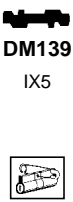
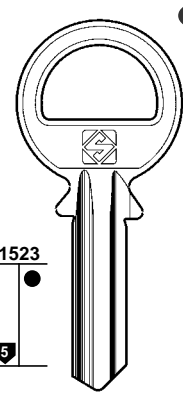
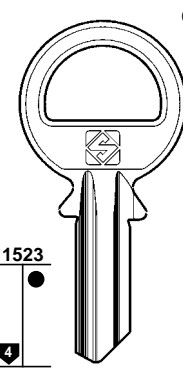

1

PER / FOR
606 (RA)
DOM (D)
MERLE (RA)
YALTRES (RA)

PER:
FOR:



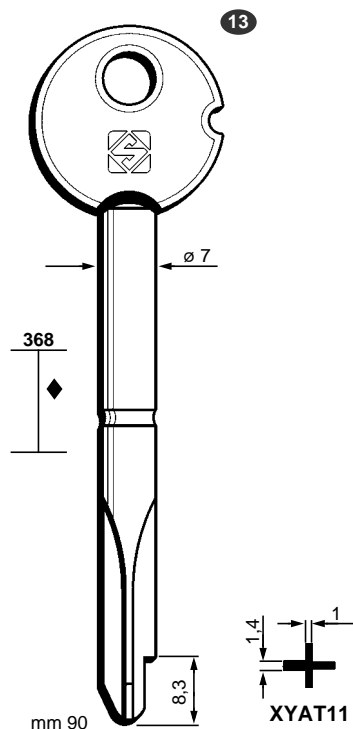







YALTRES













01
COMMERCIAL GROUP
GRUPPO COMMERCIALE
PREISEGRUPPE
GROUPE COMMERCIAL
GRUPO COMMERCIAL



www.silca.it

TRANSPONDER LEGEND

1		<p>Make and model Marca e modello Marke und Modell Marque et modèle Marca y modelo</p>	5		<ul style="list-style-type: none"> - M = MASTER: llave primaria, abre todas las cerraduras; - V = VALET: llave secundaria, sólo para encendido vehículo y abertura portezuela. - P = tapón de la cabeza de la llave - R = tapón rojo; - W = tapón blanco; - B = tapón azul; - HK = color de la cabeza de la llave.
2		<p>In production from... Fabbricata dal... Hergestellt seit... Fabriquée du... Fabricada desde...</p>	6		<ul style="list-style-type: none"> • Type of transponder on the original key⁽¹⁾ • Tipo di transponder presente nella chiave originale⁽¹⁾ • Transpondertyp im Originalschlüssel⁽¹⁾ • Type de transpondeur présent dans la clé originale⁽¹⁾ • Tipo de transponder presente en la llave original⁽¹⁾
2/a		<p>In production until... Fabbricata fino al... Hergestellt bis... Fabriquée jusqu'au... Fabricada hasta...</p>	9		<ul style="list-style-type: none"> • Identification of transponder type by RW2 (with stand alone or PC) ⁽²⁾ • Identificazione tipo di transponder tramite RW2 (sia in modalità stand alone che con PC) ⁽²⁾ • Identifizierung des Transpondertyps mit Hilfe der RW2 (sowohl Stand Alone als auch mit PC) ⁽²⁾ • Identification du type de transpondeur par RW2 (tant en mode "stand alone" qu'avec PC) ⁽²⁾ • Identificación tipo de transponder por medio de RW2 (tanto en modalidad stand alone como con PC) ⁽²⁾
3		<p>Silca key reference Referenza chiave Silca Silca-Schlüssel-Referenz Référence clé Silca Referencia llave Silca</p>	9/a		<ul style="list-style-type: none"> • Identification of transponder type by RW2+TEX Code ⁽³⁾ • Identificazione tipo di transponder tramite RW2+TEX Code ⁽³⁾ • Identifizierung des Transpondertyps mit Hilfe der RW2+TEX Code ⁽³⁾ • Identification du type de transpondeur par RW2+TEX Code ⁽³⁾ • Identificación tipo de transponder por medio de RW2+TEX Code ⁽³⁾
5		<ul style="list-style-type: none"> - M = MASTER: primary key, opens all locks; - V = VALET: secondary key, for vehicle ignition and door opening only; - P = key head plug - R = red plug; - W = white plug; - B = Blue plug; - HK= key head color. <ul style="list-style-type: none"> - M = MASTER: chiave primaria, apre tutte le serrature; - V = VALET: chiave secondaria, solo per accensione auto e apertura portiera; - P = tappo testa chiave; - R = tappo rosso; - W = tappo bianco; - B = tappo blu; - HK= colore testa chiave. <ul style="list-style-type: none"> - M = MASTER: Primärschlüssel, öffnet alle Schlösser; - V = VALET: Sekundärschlüssel nur zum Starten des Schlüssels und Öffnen der Tür; - P = Gehäuse - R = Rote Gehäuse; - W = Weisse Gehäuse; - B = Blaue Gehäuse; - HK= Kopf-Farbe. <ul style="list-style-type: none"> - M = MASTER: clé primaire ouvrant toutes les serrures; - V = VALET: clé secondaire pour allumage voiture et ouverture de la portière seulement. - P = bouchon tête clé - R = bouchon rouge; - W = bouchon blanche; - B = bouchon bleue; - HK= couleur tête clé. 	10		<ul style="list-style-type: none"> • Copy of key by RW2 (version 27.0) The symbols show: <ul style="list-style-type: none"> - Y: can be copied with RW2 (RW2 Stand Alone); - ID: The RW2 (latest version in Silca) is able to duplicate the ID (part of the electronic code) of Philips Crypto transponders. • Copia della chiave tramite RW2 (versione 27.0) I simboli identificano: <ul style="list-style-type: none"> - Y: copiabile con RW2 (RW2 Stand Alone); - ID: RW2 (ultima versione presente in Silca) è in grado di duplicare l'identificatore (parte del codice elettronico) del transponder Crypto Philips. • Kopie des Schlüssels mit RW2 (Version 27.0) Die Symbole zeigen an: <ul style="list-style-type: none"> - Y: kopierbar mit RW2 (RW2 Stand Alone); - ID: RW2 (letzte Version von Silca) kopiert den Identifikator (Teil des elektronischen Codes) des Transponders Crypto Philips.

10	 RW2	<p>Copie de la clé par RW2 (version 27.0) Les symboles indiquent:</p> <ul style="list-style-type: none"> - Y: copiable avec RW2 (RW2 Stand Alone); - ID: RW2 (dernière version présente chez Silca) est en mesure de reproduire l'identificateur (partie du code électronique) du transpondeur Crypto Philips. <p>Copia de la llave por medio de RW2 (versión 27.0) Los símbolos identifican:</p> <ul style="list-style-type: none"> - Y: copiable con RW2 (RW2 Stand Alone); - ID: RW2 (última versión presente en Silca) es capaz de duplicar el identificador (parte del código electrónico) del transponder Crypto Philips.
10/a	 RW2 + Tex Code	<p>Copy of key (Texas* 4C) by RW2 (version 27.0) + Tex Code + electronic key.</p> <p>Copia della chiave (Texas* 4C) tramite RW2 (versione 27.0) + Tex Code + chiave elettronica.</p> <p>Kopie des Schlüssels (Texas* 4C) mit RW2 (Version 27.0) + Tex Code + Elektronikschlüssel.</p> <p>Copie de la clé (Texas* 4C) par RW2 (version 27.0) + Tex Code + clé électronique.</p> <p>Copia de la llave (Texas* 4C) por medio de RW2 (versión 27.0) + Tex Code + llave electrónica.</p>
11	 SA1 RW100	<p>Copy of key by RW100 and SA1</p> <p>Copia della chiave tramite RW100 ed SA1</p> <p>Kopie des Schlüssels mit RW100 und SA1</p> <p>Copie de la clé par RW100 et SA1</p> <p>Copia de la llave por medio de RW100 y SA1</p>
12	 RW2 STP	<p>Indicates the possibility to generate codes for new transponder keys using RW2/STP (Silca's latest vers.) (A)</p> <p>Indica la possibilità di generare il codice per nuove chiavi transponder utilizzando RW2/STP (l'ultima versione presente in Silca) (A)</p> <p>Zeigt an, daß der Code für neue Transponderschlüssel mit dem RW2/STP (letzte erhältliche Version) generiert werden kann (A)</p> <p>Indique la possibilité de générer le code pour de nouvelles clés transponder en utilisant RW2/STP (la dernière version présente chez Silca) (A)</p> <p>Indica la posibilidad de generar el código para nuevas llaves transponder utilizando RW2/STP (la última versión Silca) (A)</p>
15	  	<p>Key memorization procedure on the vehicle without using devices (instructions in the STP program)</p> <p>Tipo di procedura di memorizzazione della chiave sull'autovettura senza l'utilizzo di dispositivi (istruzioni all'interno del programma STP)</p> <p>Speicherung des Schlüssels im Auto ohne Verwendung der Vorrichtungen (Anleitungen im Programm STP)</p> <p>Procédure de mise en mémoire de la clé sur le véhicule sans utiliser de dispositifs (voir instructions dans le programme STP)</p> <p>Procedimiento de memorización de la llave en el vehículo sin el uso de dispositivos (instrucciones en el interior del programa STP)</p>

16	  	<p>Memorization of new keys in vehicle central immobilizer system:</p> <ul style="list-style-type: none"> - Sd: only through dealer, using the original device; the original devices are indicated on the column 16 and are for example DART, FDS2000, PGM, etc. - Nd: Memorization procedure not available. <p>Memorizzazione di nuove chiavi nella centralina immobilizer dell'auto:</p> <ul style="list-style-type: none"> - Sd: solo tramite concessionario utilizzando il dispositivo originale; i nomi dei dispositivi specifici per marca auto sono richiamati nella colonna 16 e sono per es.: DART, FDS 2000, PGM, ecc.; - Nd: non è disponibile un'eventuale procedura di memorizzazione. <p>Speicherung von neuen Schlüsseln in der Steuerzentrale des Autos:</p> <ul style="list-style-type: none"> - Sd: nur durch den Händler mit Hilfe der Originalvorrichtung; Die Namen der spezifischen Vorrichtungen gemaess der Auto-Marke sind in der Kolonne 16 erwähnt und sind zum Beispiel: DART, FDS 2000, PGM, ecc.; - Nd: kein Speicherungsverfahren verfügbar. <p>Mise en mémoire de nouvelles clés dans le central immobiliseur du véhicule:</p> <ul style="list-style-type: none"> - Sd: uniquement par l'intermédiaire du concessionnaire en utilisant le dispositif original. Les noms des dispositifs spécifiques par marque de voiture sont reportés sur la colonne 16, sont pour exemple: DART, FDS 2000, PGM, etc. - Nd: la procédure de mise en mémoire n'est pas disponible. <p>Memorización de nuevas llaves en la centralita immobilizer del vehículo:</p> <ul style="list-style-type: none"> - Sd: sólo a través del concesionario utilizando el dispositivo original (Véase en la columna 16 los nombres de los dispositivos específicos por cada marca de automóvil; por ejemplo DART, FDS 2000, PGM, etc.); - Nd: no está disponible el procedimiento de memorización.
----	--	---

All the following information reported in columns 5, 6, 9, 9a, 10, 10a, 11, 12, 15, 16, are relative to car/motorcycle/truck ignition.

Tutti i simboli e le informazioni contenute nelle colonne 5, 6, 9, 9a, 10, 10a, 11, 12, 15, 16, sono relative all'accensione dell'auto/motocicletta/camion.

Alle Symbole u. Informationen in den Spalten 5, 6, 9, 9a, 10, 10a, 11, 12, 15, 16, beziehen sich auf die Zündung des Autos/Motorrads/LKW.

Tous les symboles et les informations reportées dans les colonnes 5, 6, 9, 9a, 10, 10a, 11, 12, 15, 16, sont relatifs à l'allumage de la voiture/motocyclette/camion.

Todos los símbolos y las informaciones en las columnas 5, 6, 9, 9a, 10, 10a, 11, 12, 15, 16, son relativas al encendido del coche/motocicleta/camion.

(1)	"PH"	Transponder Philips*
	"PH / CR"	Transponder Philips* Crypto
	"MEG"	Transponder Megamos*
	"MEG / CR"	Transponder Megamos* Crypto
	"TEXAS"	Transponder Texas*
	"TEX / CR"	Transponder Texas*Crypto
	"TEMIC"	Transponder Temic*
	"MOTOR"	Transponder Motorola*
	"TEM / CR"	Transponder Temic*Crypto
	"SAAB"	Transponder Saab*

(2) NR.Transponder

- 11 Temic* (Fiat – fixed code) (Fiat - codice fisso) (Fiat - Fixer Code) (Fiat - code fixe) (Fiat - código fijo)
- 12 Temic* (Mazda-fixed code) (Mazda - codice fisso) (Mazda - Fixer Code) (Mazda - code fixe) (Mazda - código fijo)
- 13 Megamos* (fixed code) (codice fisso) (Fixer Code) (code fixe) (código fijo)
- 21 Silca (fixed code – empty) (codice fisso - vuoto) (silca Fixer Code - leer) (fixe code - vide) (código fijo - vacío)
- 22 Silca (fixed code – empty) (codice fisso - vuoto) (silca Fixer Code - leer) (fixe code - vide) (código fijo - vacío)
- 23 Silca (fixed code – empty) (codice fisso - vuoto) (silca Fixer Code - leer) (fixe code - vide) (código fijo - vacío)
- 33 Philips* (read/ write - fixed code) (read/ write - codice fisso) (read/ write - Fixer Code) (read/ write - code fixe) (read/ write - código fijo)
- 40 Philips* Crypto (Opel*-Vauxhall*)
- 41 Philips* Crypto (Nissan*)
- 42 Philips* Crypto (VAG*)
- 44 Philips* Crypto
- 45 Philips* Crypto (Peugeot*)
- 46 Philips* Crypto (Second generation) (seconda generazione) (Zweite Generation) (Deuxième génération) (segunda generati6n)
- 48 Megamos* Crypto
- 53 Philips* (emulation of Megamos* for Audi*) (emulazione di Megamos* per Audi*) (simuliert Megamos* für Audi*) (émulation de Megamos* pour Audi*) (emulaci6n de Megamos* para Audi*)
- 73 Philips* (multi block - fixed code) (multi blocco – codice fisso) (multi block - Fixer Code) (multi bloc - code fixe) (multi bloque - código fijo)
- 93 Philips* (emulation of Megamos* for Daewoo*) (emulazione di Megamos* per Daewoo*) (simuliert Megamos* für Daewoo*) (émulation de Megamos* pour Daewoo*) (emulaci6n de Megamos* para Audi*)
- 4C Texas* (fixed code) (codice fisso) (Fixer Code) (code fixe) (código fijo)
- 4D Texas* Crypto
- 8C Temic* Crypto
- 8D per Saab* (non duplicabile) (not duplicable) (nicht kopierbar) (non reproductible) (no duplicable)

(3) NR.Transponder

- 60 Texas* Crypto
- 61 Texas* Crypto Mitsubishi 3
- 62 Texas* Crypto Mitsubishi 2
- 63 Texas* Crypto Ford 2
- 64 Texas* Crypto (Renault <2000, Chrysler, Jeep)
- 65 Texas* Crypto (Suzuki)
- 67 Texas* Crypto (Toyota/Lexus)

(4)	"MEG"	Megamos* (type of generation) (tipo di generazione) (Erzeugung Typ) (Type de génération) (tipo de generaci6n)
	"B - F"	Bosch* - Fiat* (type of generation) (tipo di generazione) (Erzeugung Typ) (Type de génération) (tipo de generaci6n)
	"S - O"	Siemens* - Opel* (type of generation) (tipo di generazione) (Erzeugung Typ) (Type de génération) (tipo de generaci6n)
	"M - V"	Megamos* - VDO* (type of generation) (tipo di generazione) (Erzeugung Typ) (Type de génération) (tipo de generaci6n)
	"T - F"	Temic* - Fiat* (type of generation) (tipo di generazione) (Erzeugung Typ) (Type de génération) (tipo de generaci6n)
	"S - V"	Siemens* - Volkswagen* (type of generation) (tipo di generazione) (Erzeugung Typ) (Type de génération) (tipo de generaci6n)
	"G - V"	PSA* - Valeo* (type of generation) (tipo di generazione) (Erzeugung Typ) (Type de génération) (tipo de generaci6n)
	"G - C"	PSA* - CPH* (type of generation) (tipo di generazione) (Erzeugung Typ) (Type de génération) (tipo de generaci6n)
	"N - N"	Nissan* (type of generation) (tipo di generazione) (Erzeugung Typ) (type de génération) (tipo de generaci6n)

The keys must then be memorized in the vehicle central immobilizer system.

Le chiavi devono poi essere memorizzate nella centralina immobilizer dell'auto.

Die Schlüssel müssen anschliessend in die Steuerzentrale der Wegfahrsperrung des Autos eingespeichert werden.

Les clés doivent être mises en mémoire dans le central immobiliseur du véhicule.

Las llaves deben memorizarse en la centralita immobilizer del vehículo.

(*) Registered trade marks.

Marchi registrati.

Registrierte Handelsmarken.

Marques déposées.

Marcas registradas.



CAR KEYS SECTION

1	2	2/A	3	5	6	9	9/a	10	10/a	11	12	15	16	A	B	C	D
	FROM 1995	TO 2005	Ref. 	M V 		ID 	Tex Code ID 	RW2 	RW2 v.27.0 + Tex Code 	SA1 RW100 	STP/ RW2 						
LDV																	
CONVOY	1998	2000	FO19EH1		TEXAS	4C			Y					←	←		←
CUB	1998	2000	FO19EH1		TEXAS	4C			Y					←	←		←
MITSUBISHI																	
PAJERO IO	1999				TEX / CR	4D	61						Sd	←	←		
PAJERO PININ	1999				TEX / CR	4D	61						Sd	←	←		
NISSAN																	
NAVARA	2004		NSN14T13		TEX / CR	4D	XX						Sd	←	←		←
NAVARA	2004		NSN14AT13		TEX / CR	4D	XX						Sd	←	←		←
PATROL	2004		NSN14T13		TEX / CR	4D	XX						Sd	←	←		←
PATROL	2004		NSN14AT13		TEX / CR	4D	XX						Sd	←	←		←
VANETTE CARGO	1999		NSN11T13	P/R	TEX / CR	4D	60						Sd	←	←		←
VANETTE CARGO	1999		NSN11AT13	P/R	TEX / CR	4D	60						Sd	←	←		←
X-TRAIL	2004		NSN14T13		TEX / CR	4D	XX						Sd	←	←		←
X-TRAIL	2004		NSN14AT13		TEX / CR	4D	XX						Sd	←	←		←
PEUGEOT																	
107	2005				TEX / CR	4D	XX						Sd	←	←		←
607	2004		NE78T14		PH / CR	46							Sd	←			←
1007	2005		VA2T14		PH / CR	46							Sd	←	←	←	←
SUZUKI																	
GRAND VITARA	1996	2002	SZ11RT4		TEXAS	4C							Sd	←	←		←
GRAND VITARA	1996	2002	SZ11REH1		TEXAS	4C			Y					←	←		←
GRAND VITARA	1996	2002	SZ12T4		TEXAS	4C							Sd	←	←		←
GRAND VITARA	1996	2002	SZ12EH1		TEXAS	4C			Y					←	←		←
GRAND VITARA	2002				PH / CR	46							Sd	←	←		
IGNIS	2000		HU87RT9		PH / CR	40		ID					Sd	←	←		←
WAGON R	2000		HU87RT9		PH / CR	40		ID					Sd	←	←	←	←

SW-SDD UPDATE 1° 2005

Code / Codice D729709ZB



GB

Now available the 1st "SDD-SW UPDATE 1° 2005", introducing new features and data base.











- Improved viewing of Volkswagen database;
- New Greek language version;
- 14 car makes with other 150 models.

I











È disponibile il nuovo aggiornamento Software "SDD-SW 1° 2005", che introduce numerose novità sia in termini di dato che di funzioni.

- Migliorata funzione del data base Volkswagen;
- Nuova versione in lingua greca;
- 14 marche auto per oltre 150 modelli.









FIAT GROUP

	FROM  1996,	TO  2004,	 Ref.	 Ico U.S.A. Ref.	 ID	Tex Code ID 	 RW2 STP		
ALFA ROMEO									
147	2000				MEG / CR	48		16_02	00
156	1998	2001			PH / CR	44		16_02	00
156	2001	2003			PH / CR	46		16_02	00
156	2003				MEG / CR	48		16_02	00
166	1998	2004			PH / CR	44		16_02	00
166	2004				PH / CR	46		16_02	00
156 SPORT WAGON	2000	2001			PH / CR	44		16_02	00
156 SPORT WAGON	2001				PH / CR	46		16_02	00
GT	2004				MEG / CR	48		16_02	00
FIAT									
DAILY	2000				PH / CR	46		16_02	00
DOBLO'	2000				MEG / CR	48		16_02	00
DUCATO	2002				MEG / CR	48		16_02	00
IDEA	2003				MEG / CR	48		16_02	00
MULTIPLA	1998				MEG / CR	48		16_02	00
PALIO	2002				MEG / CR	48		16_02	00
PANDA	2002				PH / CR	46		16_02	00
PUNTO	1999				MEG / CR	48		16_02	00
SEICENTO	2000				MEG / CR	48		16_02	00
STILO	2001				MEG / CR	48		16_02	00
ULISSE	2002				PH / CR	46		16_02	00
FIAT PSA									
PHEDRA [BSI]	2002				PH / CR	46		16_02	00
SCUDO [SC]	1999	2002			PH		G-C	10_00	00
SCUDO [SV]	1999	2002			PH		G-V	10_00	00
ULISSE [BSI]	2002				PH / CR	46		16_02	00
LANCIA									
LYBRA	1999				MEG / CR	48		16_02	00
PHEDRA	2002				PH / CR	46		16_02	00
THESIS	2002				MEG / CR	48		16_02	00
YPSILON	2003				PH / CR	46		16_02	00











CITROEN

		TO  2004,	 Ref.	 Ico U.S.A. Ref.	 ID	Tex Code ID 	 RW2 STP		
CITROEN									
C2	2005		VA2T14		PH / CR	46		18_01	00
C8	2002				PH / CR	44		18_01	00











CHRYSLER GROUP

	FROM  1996,	TO  2004,	 Ref.	 Ico U.S.A. Ref.	 ID	Tex Code ID 	 RW2 STP		
CHRYSLER									
300 [CAN]	2004				TEX / CR	4D		18_00	00
SEBRING [CCD]	1998	2002	Y160-PT	Y160-PT	TEX / CR	4D	64	18_00	00+13
STRATUS [CCD]	1999	2001	Y160-PT	Y160-PT	TEX / CR	4D	64	18_00	00-13
TOWN&COUNTRY	2004				TEX / CR	4D		18_00	09
VOYAGER [CCD]	1998	2000	Y160-PT	Y160-PT	TEX / CR	4D	64	18_00	00-13
VOYAGER	2004				TEX / CR	4D	64	18_00	09
DODGE									
Caravan	2004				TEX / CR	4D		18_00	09
DAKOTA [CAN]	2004	2005			TEX / CR	4D		18_00	00
DURANGO [CAN]	2004	2005			TEX / CR	4D		18_00	00
MAGNUM [CAN]	2005				TEX / CR	4D		18_00	00
STRATUS [CCD]	1999	2001	Y160-PT		TEX / CR	4D	64	18_00	00-13
JEEP									
CHEROKEE [CCD]	1998	2002	Y160-PT	Y160-PT	TEX / CR	4D	64	18_00	00-13
G.CHEROKEE [CAN]	2005				TEX / CR	4D		18_00	00
LIBERTY	2005				TEX / CR	4D	64	18_00	09
WRANGLER [CCD]	1999	2001	Y160-PT	Y160-PT	TEX / CR	4D	64	18_00	00-13











LEXUS/TOYOTA

	FROM 	TO 	 Ref.	 U.S.A. Ref.	 ID	Tex Code ID 	 RW2 STP		
LEXUS									
ES300	2002	2003	TOY48BT4	TOY48BT4	TEXAS	4C		15_00	0
ES330	2004	2005			TEX / CR	4D	XX	15_00	0
GS300	2002	2005	TOY48BT4	TOY48BT4	TEXAS	4C		15_00	0
GS430	2001	2005	TOY48BT4	TOY48BT4	TEXAS	4C		15_00	0
GX470	2003	2005			TEX / CR	4D	XX	15_00	0
IS300	2002	2005	TOY48BT4	TOY48BT4	TEXAS	4C		15_00	0
LS430	2001	2004			TEX / CR	4D	XX	15_00	0
LS430	2004		SMART KEY	SMART KEY	TEX / CR	4D	XX	15_00	0
LX470	2001	2002	TOY48BT4	TOY48BT4	TEXAS	4C		15_00	0
LX470	2003	2005			TEX / CR	4D	XX	15_00	0
RX330	2004	2005			TEX / CR	4D	XX	15_00	0
SC430	2002	2005			TEX / CR	4D	XX	15_00	0
TOYOTA									
4Runner	2001	2002	TOY43AT4	TOY43AT4	TEXAS	4C		15_00	0
4Runner	2003	2005			TEX / CR	4D	XX	15_00	0
CAMRY [TYPE1]	2002	2004	TOY43AT4	TOY43AT4	TEXAS	4C		15_00	0
CAMRY [TYPE2]	2003	2004			TEX / CR	4D	XX	15_00	0
COROLLA	2005				TEX / CR	4D	XX	15_00	0
Higlander	2004	2005			TEX / CR	4D	XX	15_00	0
Higlander 4cyl	2001	2003	TOY43AT4	TOY43AT4	TEXAS	4C		15_00	0
Land Cruiser	2001	2002	TOY43AT4	TOY43AT4	TEXAS	4C		15_00	0
Land Cruiser	2003	2005			TEX / CR	4D	XX	15_00	0
MATRIX	2005				TEX / CR	4D	XX	15_00	0
PRIUS	2004		SMART KEY	SMART KEY	TEX / CR	4D	XX	15_00	0
SEQUOIA	2001	2002	TOY43AT4	TOY43AT4	TEXAS	4C		15_00	0
SIENNA	2004	2005			TEX / CR	4D	XX	15_00	0
SOLARA	2004	2005			TEX / CR	4D	XX	15_00	0
SOLARA 4cyl	2002	2003	TOY43AT4	TOY43AT4	TEXAS	4C		15_00	0











NISSAN

	FROM 	TO 	 Ref.	 U.S.A. Ref.	 ID	Tex Code ID 	 RW2 STP		
NISSAN									
350Z	2003		NI02T		TEX / CR	4D	60	N	00-05
NAVARRA	2000		NSN11T13		TEX / CR	4D	60	N	00-05
NAVARRA	2000		NSN11AT13		TEX / CR	4D	60	N	00-05
VANETTE	2000		NSN11T13		TEX / CR	4D	60	N	00-05
VANETTE	2000		NSN11AT13		TEX / CR	4D	60	N	00-05
NISSAN TRUCKS									
ATLEON	2002		NSN11AT13		TEX / CR	4D	60	18_01	
ATLEON	2002		NSN11T13		TEX / CR	4D	60	18_01	
CAB STAR	2000		NSN11AT13		TEX / CR	4D	60	18_01	
CAB STAR	2000		NSN11T13		TEX / CR	4D	60	18_01	
INTERSTAR	2002		NE73T1		PH	33		18_01	





RENAULT

	FROM 	TO 	 Ref.	 U.S.A. Ref.	 ID	Tex Code ID 	 RW2 STP		
RENAULT									
LAGUNA	2003		SMART KEY		PH / CR	46		15_2	00
MASTER	2002				PH / CR	46		15_2	00





SUZUKI

	FROM 	TO 	 Ref.	 iCO U.S.A. Ref.	 ID	Tex Code ID 	 RW2 STP		
SUZUKI									
ALTO	1996		SZ11RT4		TEXAS	4C		18_01	0
ALTO	1996		SZ12T4		TEXAS	4C		18_01	0
BALENO	1996		SZ11RT4		TEXAS	4C		18_01	0
BALENO	1996		SZ12T4		TEXAS	4C		18_01	0
GRAND VITARA	1996	2002	SZ11RT4		TEXAS	4C		18_01	0
GRAND VITARA	1996	2002	SZ12T4		TEXAS	4C		18_01	0
GRAND VITARA	2002				PH / CR	46		18_01	0
IGNIS	2000				TEX / CR	4D		18_01	0
IGNIS [D]	2000				TEX / CR	4D		18_01	0
JIMNY	1999	2002	SZ11RT4		TEXAS	4C		18_01	0
JIMNY	2002				TEX / CR	4D		18_01	0
LIANA	2001				TEX / CR	4D		18_01	0
SWIFT	1996	2005	SZ11RT4		TEXAS	4C		18_01	0
SWIFT	1996	2005	SZ12T4		TEXAS	4C		18_01	0
VITARA	1996	2002	SZ11RT4		TEXAS	4C		18_01	0
VITARA	1996	2002	SZ12T4		TEXAS	4C		18_01	0
VITARA	2002				PH / CR	46		18_01	0
WAGON R	1998	2000	SZ11RT4		TEXAS	4C		18_01	0
WAGON R	2000		HU87RT17		PH / CR	40		18_01	0
WAGON R[D]	1998	2000	SZ11RT4		TEXAS	4C		18_01	0
WAGON R[D]	2000		HU87RT12		PH / CR	40		18_01	0





RKE CHRYSLER

	FROM 	TO 			
CHRYSLER					
VOYAGER CCD	1998	2003		00+13	18_00





RKE ROVER

	FROM 	TO 			
LAND ROVER					
DEFENDER	1998	2000		00	16_01
DISCOVERY	1996	2000		00	16_01
FREELANDER	1998	2003		00	16_01
FREELANDER	2003			00	16_01
LVX	2000	2000		00	16_01
ROVER					
45	2000			00	16_01
100	1997			00	16_01
200	1997			00	16_01
400	1997	1998		00	16_01
MGF	1997	2003		00	16_01
MINI	1997	2003		00	16_01
STREETWISE	2004			00	18_01
TF	2002			00	18_01
ZR	2001			00	18_01
ZS	2001			00	18_01
ZT5	2001			00	18_01

RKE LEXUS/TOYOTA

	FROM  1996,	TO  2004,			
LEXUS					
ES300	2002	2003		0	15_00
ES330	2002	2003		0	15_00
GS300	2002	2005		0	15_00
GS430	2001	2005		0	15_00
GX470	2003	2005		0	15_00
IS300	2002	2005		0	15_00
LS430	2001	2003		0	15_00
LX470	2001	2002		0	15_00
LX470	2003	2005		0	15_00
RX330	2004	2005		0	15_00
TOYOTA					
Land Cruiser	2001	2002		00	15_00
Land Cruiser	2003	2004		00	15_00

• RKE OPEL

	FROM  1996,	TO  2004,			
OPEL					
AGILA	2000			00	13_00
CORSA ATW	2000			00	12_01
MERIVA ATW	2002			00	12_01
OMEGA ATW	1995	1999		00-02	12_01
VECTRA ATW	1998	1999		00	12_01
ZAFIRA ATW	1999			00	12_01

GB

ATTENTION!

The models not given in the SDD database Make Model Year and:

- Ford Fiesta 2001 – 2002 Petrol
- GALAXY diesel prior to 1998
- Transit 2500 TD
- JIMNY 1.5 diesel

are currently under development, so **avoid programming** the above-mentioned vehicles until Silca carries out further updating on the device. Silca cannot guarantee proper operation of the systems involved until updating has been completed.

PROGRAM INSTALLATION

See instructions booklet with CD.

I

ATTENZIONE!

I modelli **non indicati** nel database Marca Modello Anno di SDD e:

- Ford Fiesta 2001 – 2002 Benzina
- GALAXY diesel anteriore al 1998
- Transit 2500 TD
- JIMNY 1.5 diesel

sono tuttora in fase di sviluppo, pertanto **evitare di programmare** i veicoli sopracitati fintanto che Silca non provvederà ad aggiornare ulteriormente il dispositivo. Silca non può garantire il corretto funzionamento dei sistemi indicati fino ad aggiornamento avvenuto.

INSTALLAZIONE DEL PROGRAMMA

Vedi libretto istruzione allegato nel CD